

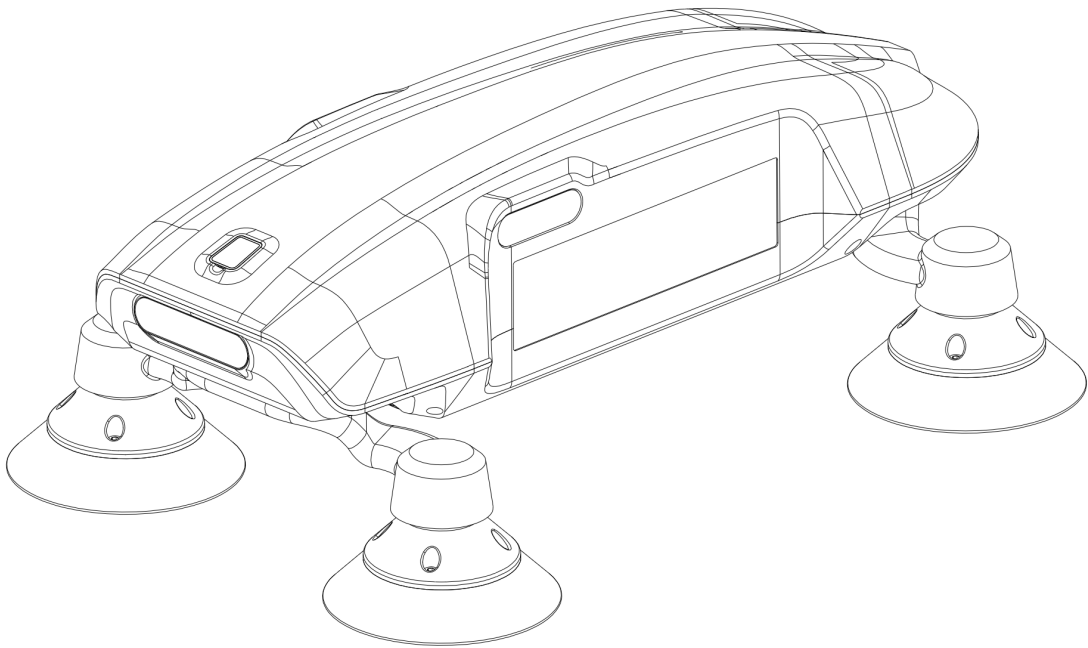

CitySense-X Environmental Mobile Monitoring System

Hardware Specifications



Soarability PTE. LTD

V1.0 2023.10.27

1. Basic Information

CitySense-X is an environmental mobile monitoring system that can be easily mounted on various public transportation vehicles (e.g., buses and taxis) and urban service vehicles (e.g., garbage trucks and law enforcement vehicles).

As the vehicles move within an area, CitySense-X automatically collects environmental data with geographical information and time stamps, which are displayed and analyzed on the accompanying CitySense.ai spatiotemporal big data analysis platform. CitySense-X also supports real-time data transmission to other platforms via MQTT.

CitySense-X can reliably collect various environmental data, including PM2.5, PM10, TSP, TVOC, and CH4, even under complex temperature and rainy/foggy conditions.

Data Upload Frequency: 1Hz.

Dimensions: 598x418x225mm.

Net Weight: Varies between approximately 4-6.5kg depending on the configuration, with the full configuration weighing about 6.5kg.

Power Supply: Vehicle cigarette lighter or cabin fuse box (12V).

Average Power Consumption: 15-35W, depending on temperature conditions and configuration.

Maximum Instantaneous Power Consumption: 45W (full configuration).

Operating Temperature: -20°C to 50°C, with the ability to regulate the temperature for internal sensors.

Operating Humidity: 0-100%RH, automatically stops air intake when condensation is present in the environment.

Protection Level: IPX4 (no need to remove from the vehicle in rainy or foggy weather).

2. Main Components

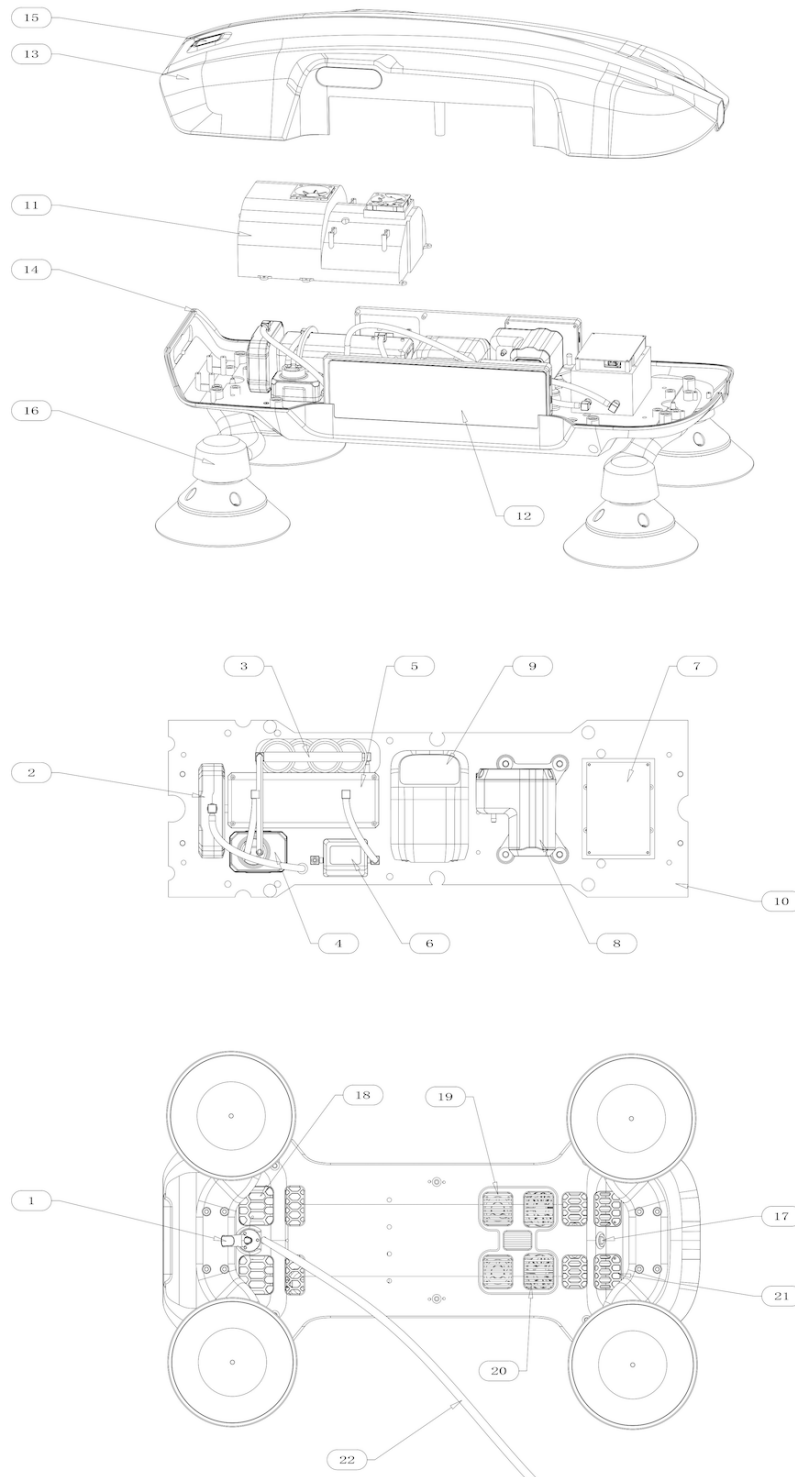

1) Air Intake Nozzle

Specially designed to prevent rain from entering the airway. The design conforms to the isokinetic sampling principle, reducing the impact of equipment movement speed on the representativeness of particulate sampling.

Features a quick-release design. During laboratory calibration, it can be easily replaced with a pagoda-shaped intake nozzle for standard gas entry.

2) Particulate Matter Monitoring Module (Optional)

Detection principle: Laser scattering.

Monitoring particle size range: 0.3-100 μ m.

Counting efficiency: 98% ($\geq 0.5\mu$ m), 50% (0.3 μ m).

Measurement resolution: 1 μ g/m³.

Linear range:

- PM_{2.5}: 0-1000 μ g/m³.
- PM₁₀: 0-1000 μ g/m³.
- PM₁₀₀/TSP: 0-2000 μ g/m³.

Instantaneous response time: <2s.

T₉₀ response time: ≤ 10 s.

PM_{2.5} measurement consistency:

- $\pm 10\%$ (100-1000 μ g/m³).
- $\pm 10\mu$ g/m³ (0-100 μ g/m³).

PM₁₀ measurement consistency:

- $\pm 15\%$ (100-1000 μ g/m³).
- $\pm 15\mu$ g/m³ (0-100 μ g/m³).

Baselines and slopes adjustment are supported via software.

Equipped with an anti-EMI shield.

Dual-laser design enhances the accuracy of large particulate matter detection.

Average mean time between failures: $\geq 20,000$ hours.

3) PM and Condensation Water Filter Module

This module includes 1x 5 μ m filter and 4x 0.45 μ m filters.

After PM is monitored, this module filters out particulates and condensation water (if any) within the gas sample, reducing interference and dust accumulation for downstream gaseous monitoring modules, thus extending the product's lifespan. It is recommended to check every 5,000 hours of use. If there is noticeable dust accumulation inside the module, it needs to be replaced.

4) TVOC Monitoring Module (Optional)

Detection principle: Ultraviolet light ionization detection (PID).

Target gas: Volatile organic compounds (VOC) with ionization potentials less than 10.6eV.

Linear range: 0-40ppm (isobutylene).

Minimum detection limit: 10ppb (isobutylene).

Startup stabilization time: ≤ 180 seconds (stabilizes to within 0.03ppm in clean air).

Repeatability: $\leq 2\%$ FS.

T₉₀ response time: <5s.

Measurement resolution: 5ppb (isobutylene).

The gas chamber has a hydrophobic membrane, significantly reducing humidity interference from 0-75%RH.

Average mean time between failures: $\geq 5,000$ hours.

5) CO₂ Monitoring Module (Optional)

Detection principle: Non-dispersive infrared (NDIR).

Optical path material: Mold steel.

Optical path length: 90mm.

Linear range: 0-2000ppm.

Minimum detection limit: 1ppm.

Measurement resolution: 1ppm.

Repeatability: $\leq 1\%$ FS.

Baseline temperature drift: $\pm 2\%$ FS.

Range drift: $\pm 2\%$ FS.

6) Airway Monitoring Module

Real-time monitoring of the gas sample's temperature, humidity, and flow rate (in SLM). Equipped with a 1.8-inch display screen for easier maintenance and inspection.

7) CH₄ Monitoring Module (Optional)

Detection principle: Internal Multi-Pass Tunable Diode Laser Absorption Spectroscopy (MP-TDLAS).

Excellent gas selectivity, sensitive only to CH₄ gas.

Linear range: 0-10,000ppm.

Minimum detection limit: 2ppm.

Measurement resolution: 1ppm (static signal standard deviation ≤ 300 ppb).

Repeatability: $< 1\%$ FS.

T90 response time: ≤ 10 s (from 0 to 1000ppm).

Features a three-stage temperature control system (shell -> gas chamber -> laser), ensuring excellent data quality within a temperature range of -20°C to 50°C .

8) Pump Module

Flow rate: 1.2SLM. The flow rate decreases when the gas path is blocked (e.g., dust accumulation inside the particulate matter and condensation water filter module).

The pump module will automatically stop when condensation water is detected in the environment, reducing the interference of rain and fog on PM measurement and extending the product's lifespan.

Can be configured to link flow rate with device movement speed, adhering to the isokinetic sampling principle.

9) Central Control Module

Responsible for:

- Aggregating data from other modules and edge computing,
- Power distribution and consumption monitoring for each module,

- Satellite + inertial positioning,
- 3G/4G communication.

Equipped with a 1.5GHz 64-bit quad-core Cortex-A53 processor and 1GB DDR3L memory.

10) Motherboard

Provides neat power supply routes, data exchange routes, and some structural support for various modules.

11) Sensor Component Compartment 1

Provides a more suitable operating temperature for CO₂, PM, and TVOC sensor modules.

12) LCD Displays

Located on both sides of the device, it has four modes: off, display user-defined images, rolling display of real-time monitoring data, and display detailed device operating status.

13) Top Cover

Made of PC+ABS material, featuring a heat reflection design.

14) Bottom Cover

Made of PC+ABS material, featuring a heat reflection design.

15) Rain Sensor

Monitors the rain and fog conditions in the environment. When condensation is present in the environment, it can trigger the pump module to stop air intake, protecting the sensing components and eliminating the interference of rain and fog on PM measurement.

16) Electronically Controlled Automatic Suction Cups

Automatically monitors the negative pressure inside the suction cups. When the negative pressure is insufficient, a warning light illuminates, and it automatically pumps to tighten. The pump has a manual shut-down feature for easy debugging and installation/removal. The suction cups feature a universal joint, adapting to installation surfaces of different curvatures.

17) Switch for the Electronically Controlled Automatic Suction Cups

Turn on/off the electronic control automatic suction cups.

18) Sensor Component Compartment 1 Heat Exchange Air Intake

19) Overall Heat Exchange Exhaust

20) CH4 Monitoring Module Heat Exchange Air Intake

21) CH4 Monitoring Module Heat Exchange Exhaust

22) Power Cable

12V waterproof power cable, flat-shaped, can withstand repeated pinching by car door seals.